

## Camshaft Phaser and Sprocket Inspection

1. Inspect the front of the camshaft phaser and sprocket for missing or damaged roll pins.
  - If the roll pins are missing or damaged, a new camshaft phaser and sprocket must be installed.

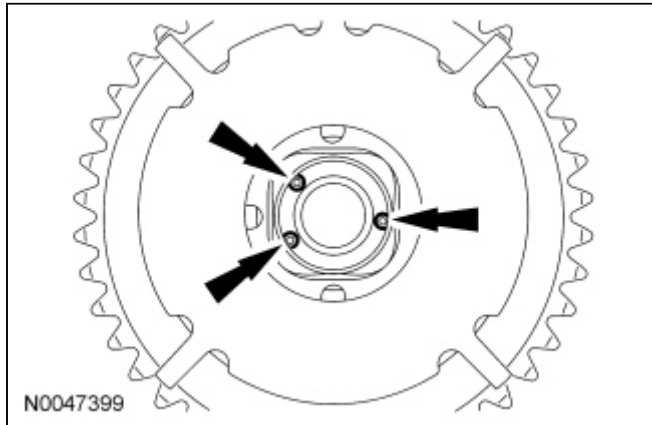

2. Inspect the rear of the camshaft phaser and sprocket for a deformed or damaged location pin.
  - If the location pin is deformed or damaged, a new camshaft phaser and sprocket must be installed.

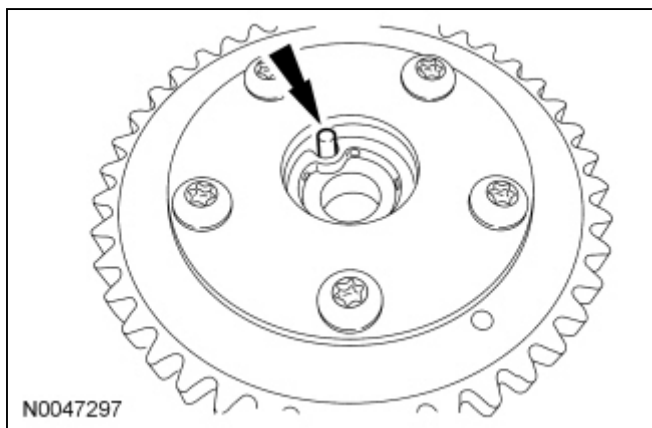

3. Visually inspect the camshaft phaser and sprocket for squareness (A). If the trigger wheel or spring is deformed or damaged (B), install a new camshaft phaser and sprocket.

A

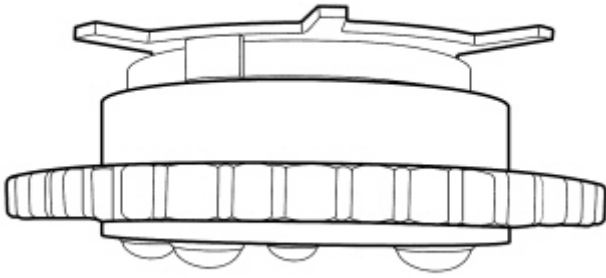

B

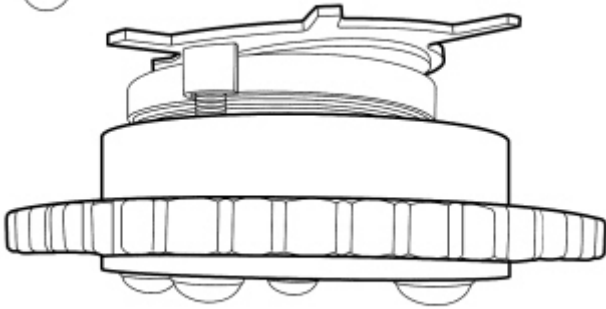

N0047574

---